

Harrison Swivel Chair • 5125 • INSTRUCTIONS

Organize your parts and hardware before you begin.

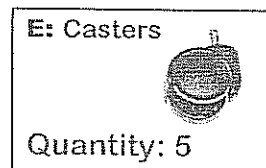

Parts :

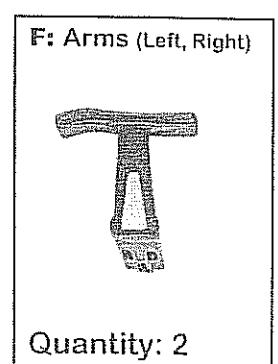
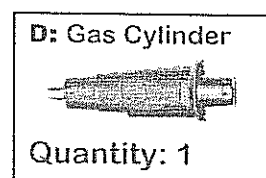
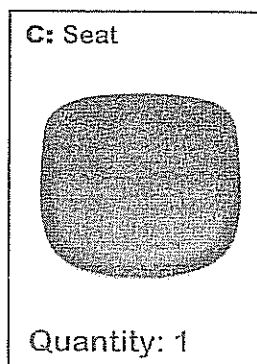
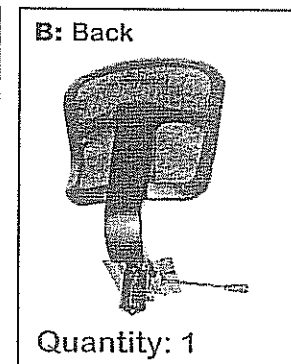
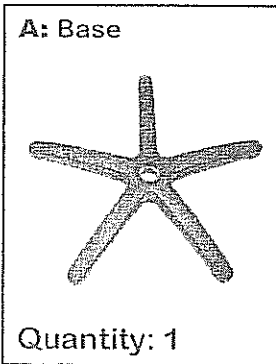

Hardware :

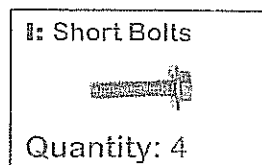
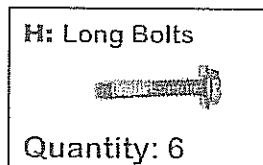
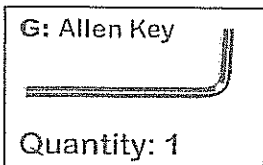

IMPORTANT NOTICE:

Place all wooden parts on a clean and smooth surface such as a rug or carpet to avoid the parts from being scratched.

Check to be sure that you have all parts and hardware.

Remove all wrapping materials, including staples & packing straps before you start to assemble.

Do not tighten all screws/bolts until completely assembled.

Keep all hardware and packaging out of reach of children.

Any problems or questions call Regency Office Furniture at 1-866-816-9822

Harrison Swivel Chair • 5125 • INSTRUCTIONS

STEP 1A: Insert 5 Casters(E) into Base(A) (figure 1).

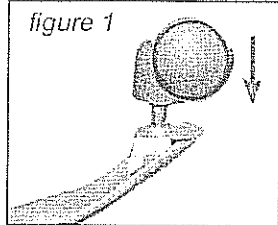
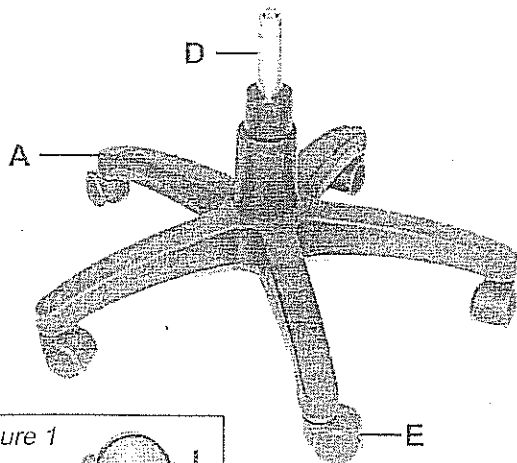

STEP 1B: Slide Gas Cylinder(D) into Base(A).

STEP 2: Attach the Back(B) to the bottom of Seat(C) using 4 Short Bolts(I).

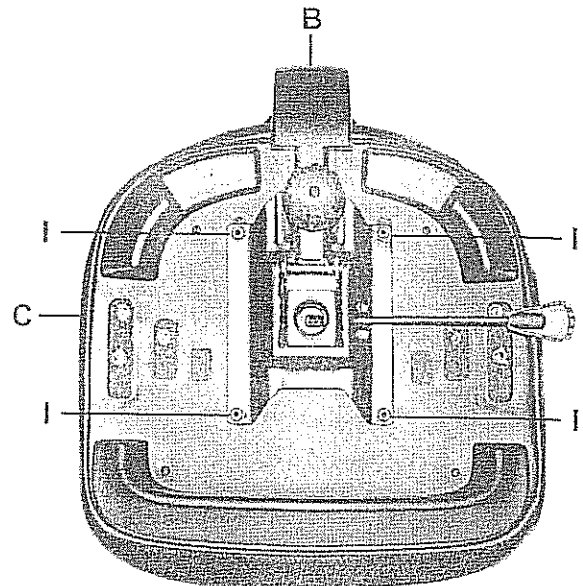

STEP 3: Attach the Arms(F) to the bottom of Seat(C) using 3 Long Bolts(H) per arm.

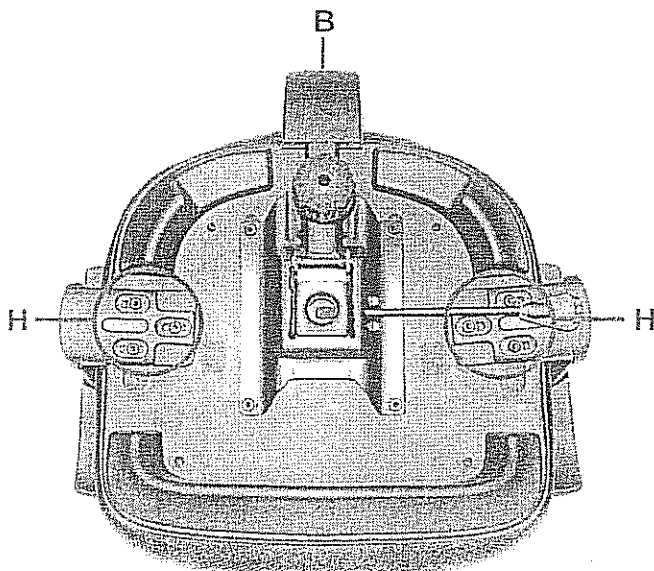

STEP 4: Place assembled Seat/Back onto Gas Cylinder(D) of Chair Base.

NOTE: APPLY PRESSURE TO THE SEAT TO ENSURE CONNECTION BEFORE USE.

