

# INSTALLATION / INSTRUCTIONS

## DESKTOP SIT-STAND WORKSTATION

### IMPORTANT INFORMATION

Lift the workstation out of the box, do not squeeze the levers until after the product is in place.

### HEIGHT ADJUSTMENT

Squeeze levers on both sides simultaneously to move workstation up and down to desired height. Release levers to lock the workstation into position. The product will not be activated when squeezing only one lever.

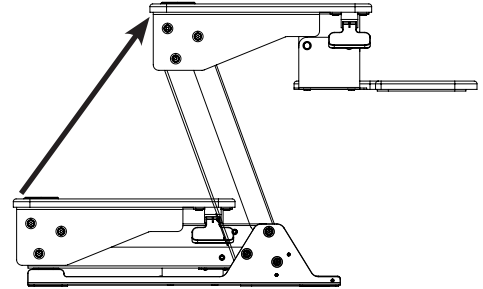

### KEYBOARD TRAY TILT ADJUSTMENT

While holding the tray, loosen knob slightly. Set and hold tray at desired tilt angle and re-tighten knob.

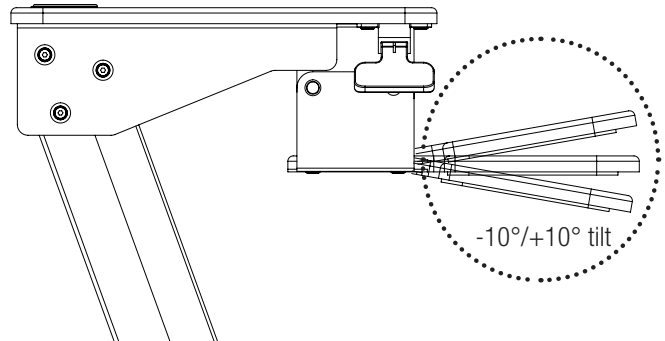
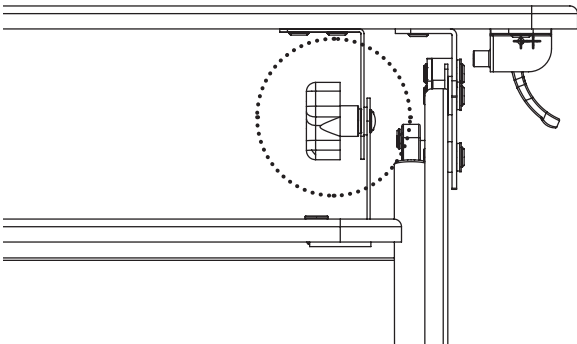

### WEIGHT CAPACITY - $A + B \leq 35$ lbs.

Maximum weight capacity is 35 lbs.  
Serious injury or property damage may occur if maximum is exceeded.

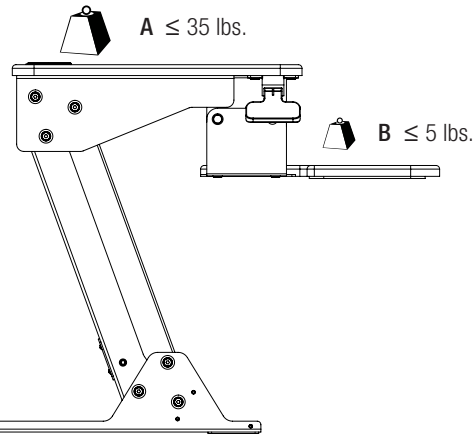

Make sure all cord lengths are sufficient to use with this product.